

REMOVABLE CAP  
POLE SHAFT

DRILLED PER FIXTURE REQUIREMENTS:  
D1- DRILLED FOR 1 FIXTURE  
D2- DRILLED FOR 2 FIXTURES AT 90° OR 180°  
D3- DRILLED FOR 3 FIXTURES AT 90° OR 120°  
D4- DRILLED FOR 4 FIXTURES

### DRILLED MOUNT OPTIONS

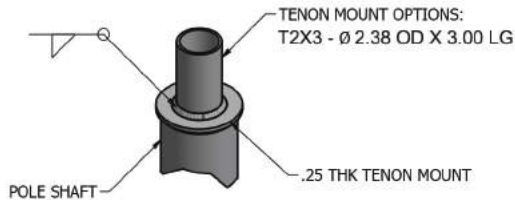

### TENON MOUNT OPTIONS



Ø.75 X 20.00 ANCHOR BOLT

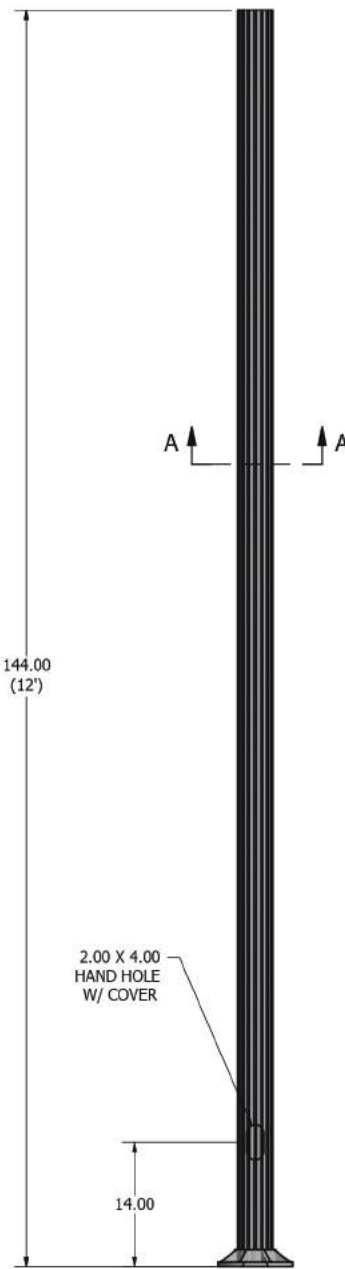

POLE DETAIL

POLE SPECIFICATIONS					
NO.	COMPONENT	MAT'L DESIGNATION			
1.	POLE SHAFT	6063-T6			
2.	BASE PLATE	A356-T6			
3.	ANCHOR BOLTS	F1554 GR. 55			
4.	GALVANIZED HARDWARE	A153			
FINISH SPECIFICATIONS					
POLES SHALL HAVE A POLYESTER POWDER COAT FINISH IN A STANDARD COLOR.					
POLE DIMENSIONS					
POLE HGT. (FT.)	TOP DIA. (IN.)	BOTTOM DIA. (IN.)	GAGE	MTG. HGT. (FT.)	
12'	4.00	4.00	0.125	12'	
BASE PLATE DIMENSIONS					
BOLT CIRCLE (IN.)	BASE PLATE DIM. (IN.)	BOLT HOLE (IN.)	PLATE THK. (IN.)		
7.00	9.00 DIA	0.88	.56		
ANCHOR BOLT DIMENSIONS					
ANCHOR BOLT DIA. (IN.)			ANCHOR BOLT LENGTH (IN.)		
0.75			20.00		
ALLOWABLE WIND LOADING (SQ. FT.)					
WIND* EPA	INDICATED EPA	80 MPH	90 MPH	100 MPH	120 MPH
		6.6	5.0	3.7	2.3

\*WITH 1.3 GUST FACTOR



2.00 X 4.00 HAND HOLE COVER



SECTION A-A  
16 FLAT FLUTE CROSS SECTION

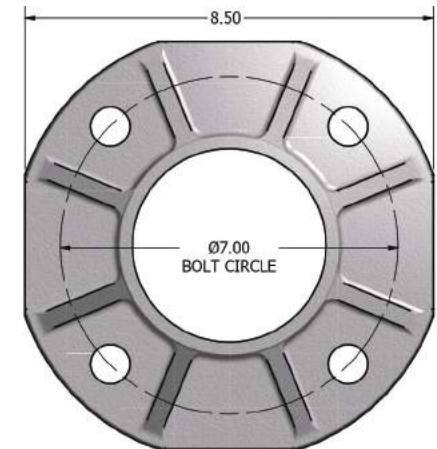

4 BOLT BASE CASTING

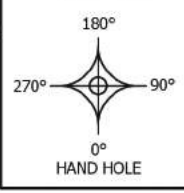

DRAWN:	3/17/2016
CHECKED:	
REVISION:	DATE:
APPROVED:	
QUOTE:	
S.O.#:	
REF:	SCALE: NONE



SOME GEOGRAPHICAL AREAS HAVE SPECIAL WIND CONDITIONS THAT CAN CREATE WIND INDUCED VIBRATIONS CAUSING A FATIGUE PROBLEM. NO METHOD HAS YET BEEN FOUND FOR PREDICTING DESTRUCTIVE LIGHTING POLE VIBRATION. THESE CONDITIONS ARE UNIQUE AND CANNOT BE GUARANTEED AGAINST, AND ARE THE RESPONSIBILITY OF A LOCAL SITE ENGINEER.

TITLE:	
CATALOG:	
DWG NO:	U-RFSA-4-12-1
SIZE:	C
SHEET	1 OF 1